

# **Risk Management and Trust in Food Safety and Quality Control**

- facts, perceptions and  
economic effects -

**why should we care?**

**Gerhard Schiefer**

International Center for  
Food Chain and Network Research  
University of Bonn

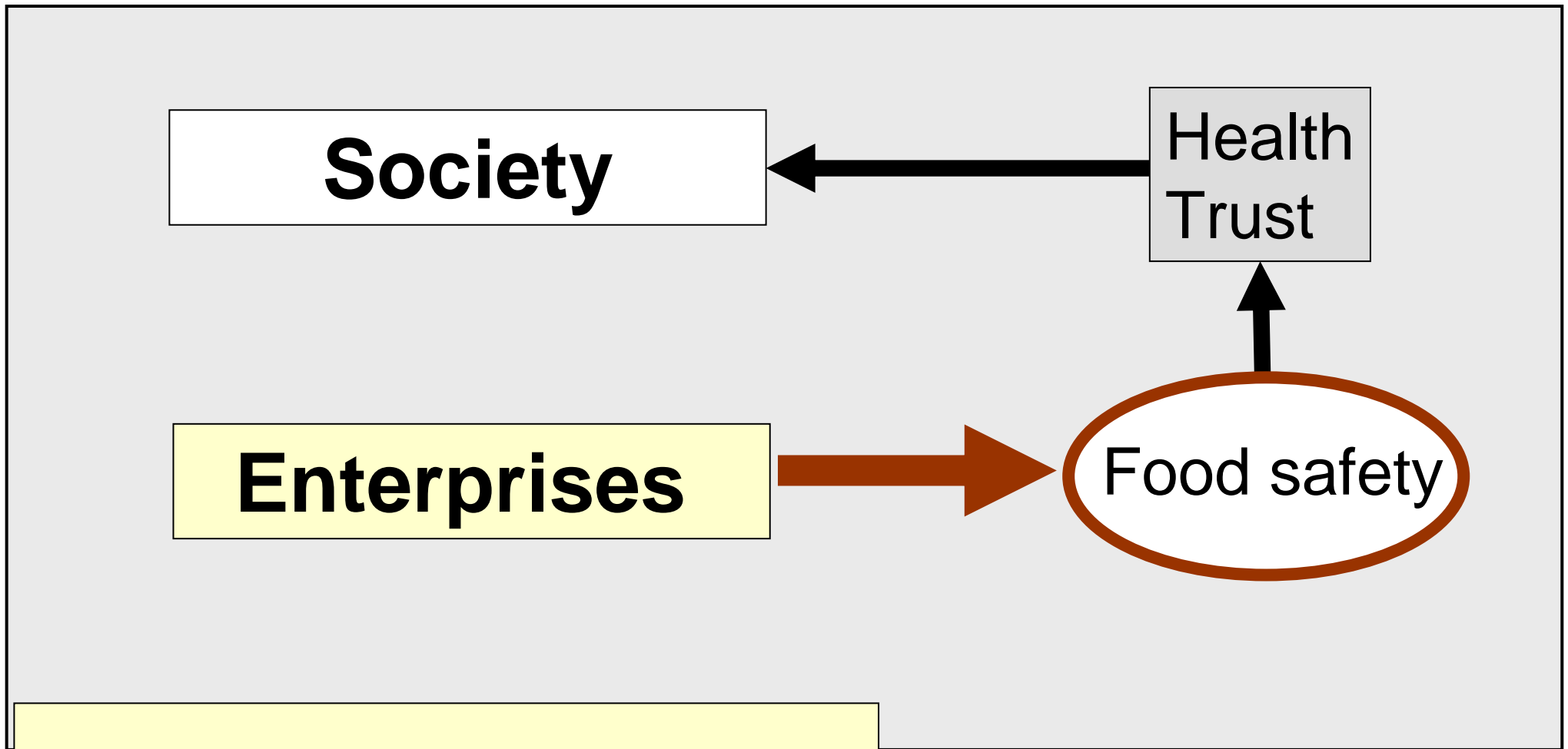

Because  
we depend on it !

# Food (Chain) Network

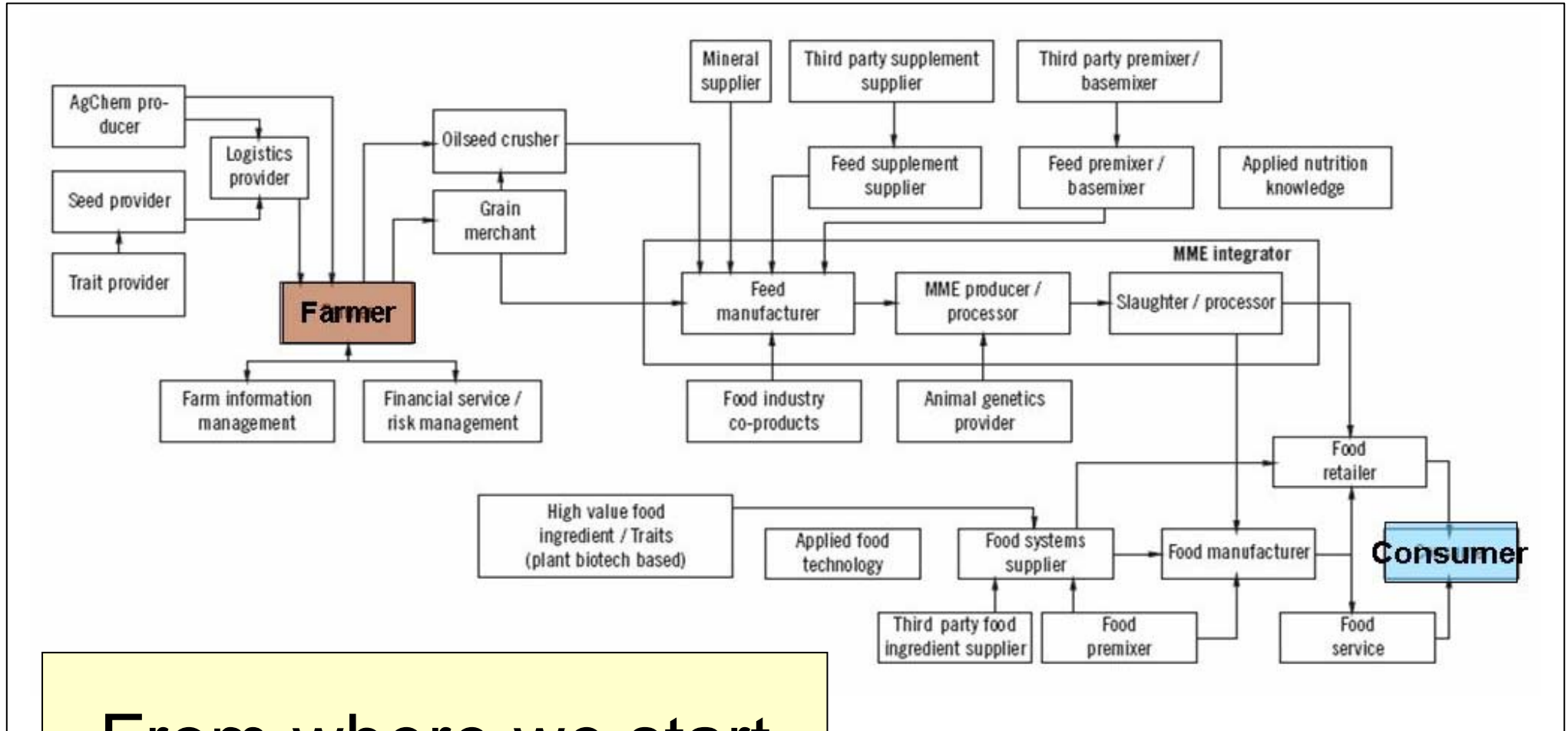

From where we start

# Challenges – the big picture

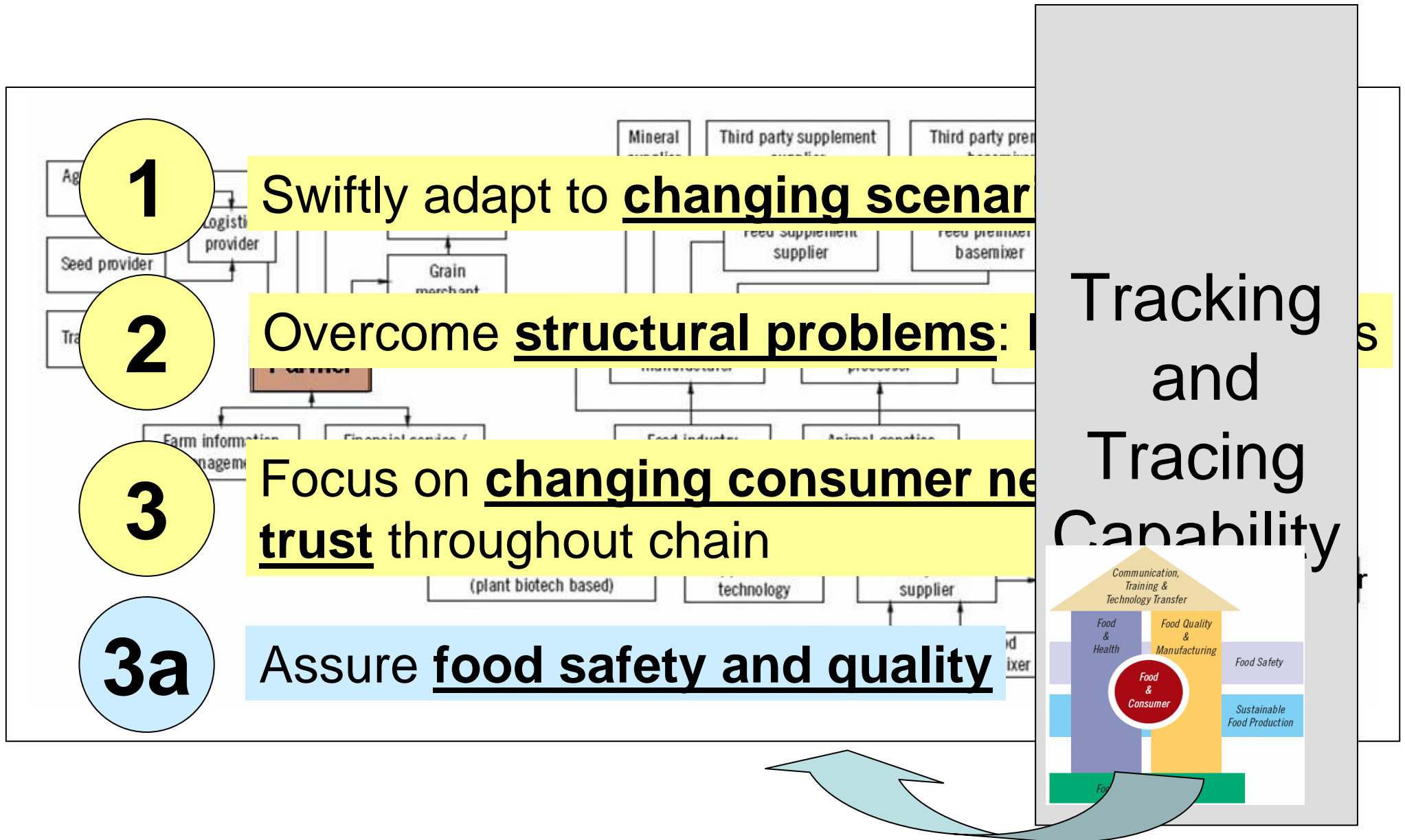

## To assure food safety:

### Are **enterprise interests** served by TT

- risk management (*recall etc...*)
- food security and market stability  
(*delivery guarantees etc...*)
- sustainability
- flexibility
- consumer trust
- process efficiency

**Enough benefits to invest ?**

**Complexity of  
food sector relationships**  
- where tracking and tracing  
needs to be organized -

# Tracking, Tracing, and Control

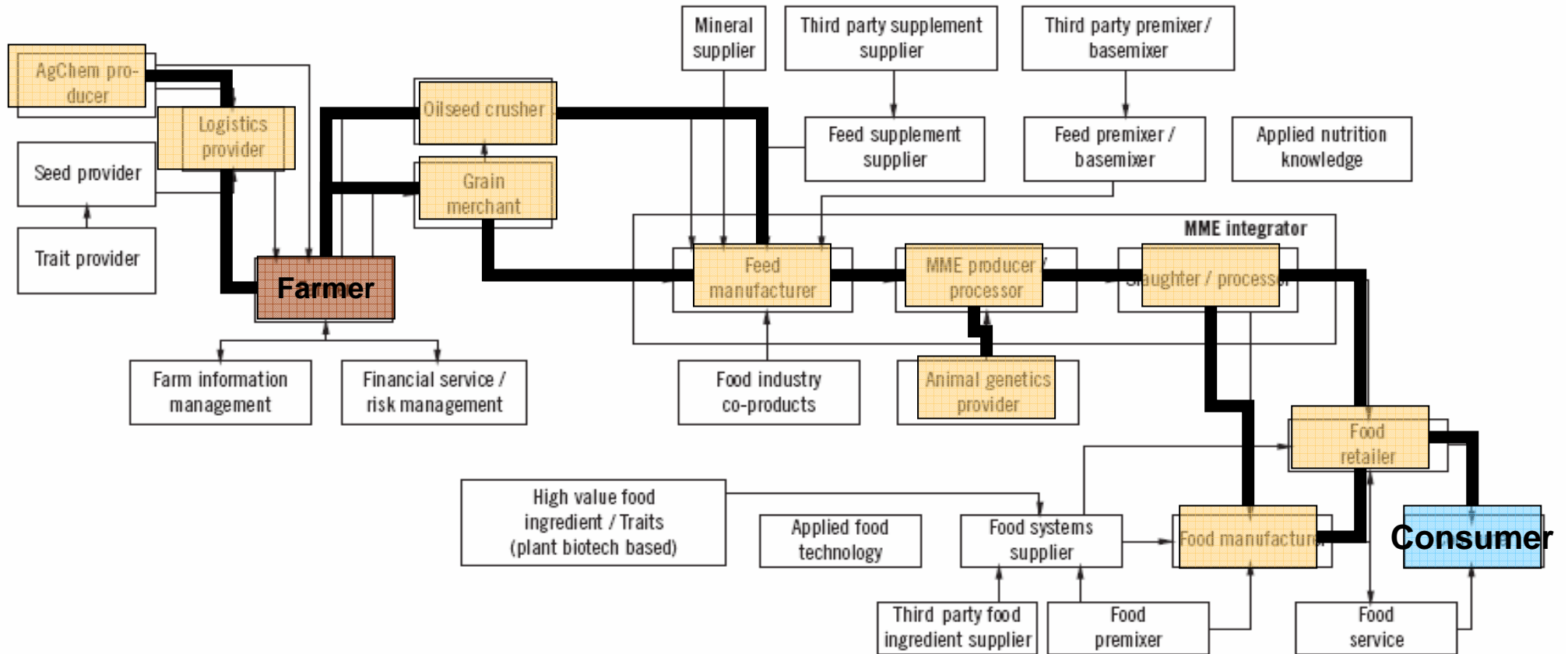

Tracking: identify position

Tracing: following product path

# Tracking, Tracing, and Control

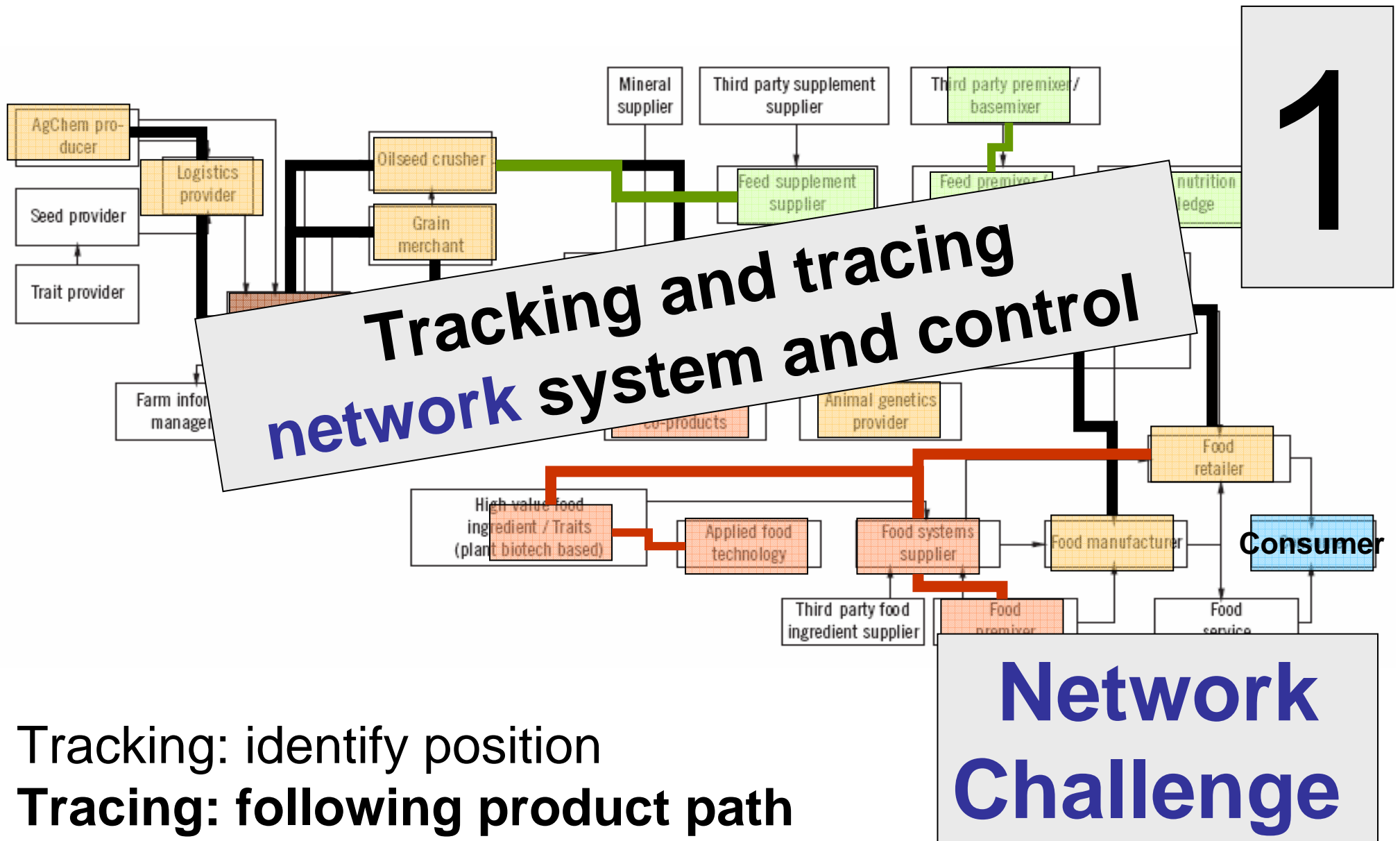

Tracking: identify position

Tracing: following product path

# How to move forward

- **TT system technologies**
- **TT information principle (organization)**
- **TT costs (real)**
- **TT benefit (potential)**
- **Cost perceptions (low)**
- **Sector dependencies of benefits**

# How to move forward

- TT system technologies
- TT information principle (organization)
- TT costs (real)
- TT benefit (potential)
- Cost perceptions (low)
- Sector dependencies of benefits

# TT system technologies

→ **Analytical** methods

- product control

→ **IT communication technology**

- communication devices (RFID)
- satellites (GPS)

→ **Organizational** data networks

- communication infrastructure

---

→ **Standardization**

# TT system technologies - capabilities

TT Functionalities	Analytical methods	Product tags (RFIDs etc.)	Information systems
<b>Backward tracing</b> (origin)	Yes	Yes	<b>Managerial opportunities + <u>challenges</u></b>
<b>Tracking</b> (position)	No	Yes	
<b>Backward tracing</b> (history)	No	No	
<b>Forward tracing</b> (movement)	No	No	

# TT system technologies - capabilities

TT Functionalities	Analytical methods	Product tags (RFIDs etc.)	Information systems
<b>Backward tracing (origin)</b>	Yes	Yes	<b>Managerial opportunities + <u>challenges</u></b>
<b>Tracking (position)</b>	No	Yes	
<b>Backward tracing (history)</b>	No	No	
<b>Forward tracing (movement)</b>	No	No	
<b>Information carrier</b>	No	Yes	
<b>Control</b>	Yes	No/(Yes)	No
<b>Complexity of implementation</b>	<b>small</b>	<b>medium</b>	<b>very high</b>

# How to move forward

- TT system technologies
- **TT information principle (organization)**
- TT costs (real)
- TT benefit (potential)
- Cost perceptions (low)
- Sector dependencies of benefits



# Principle: Tracking/tracing/control

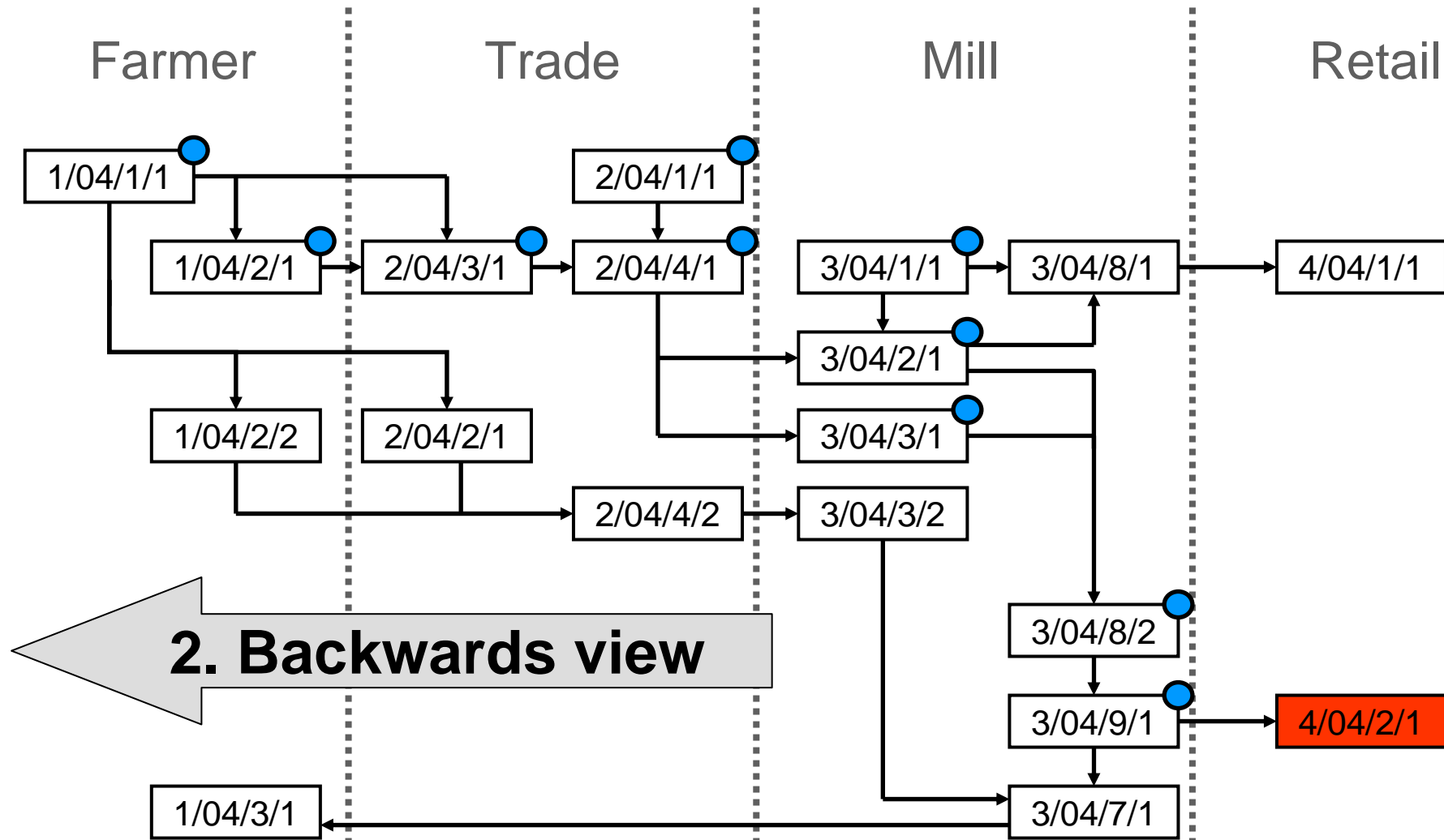

# Principle: Tracking/tracing/control

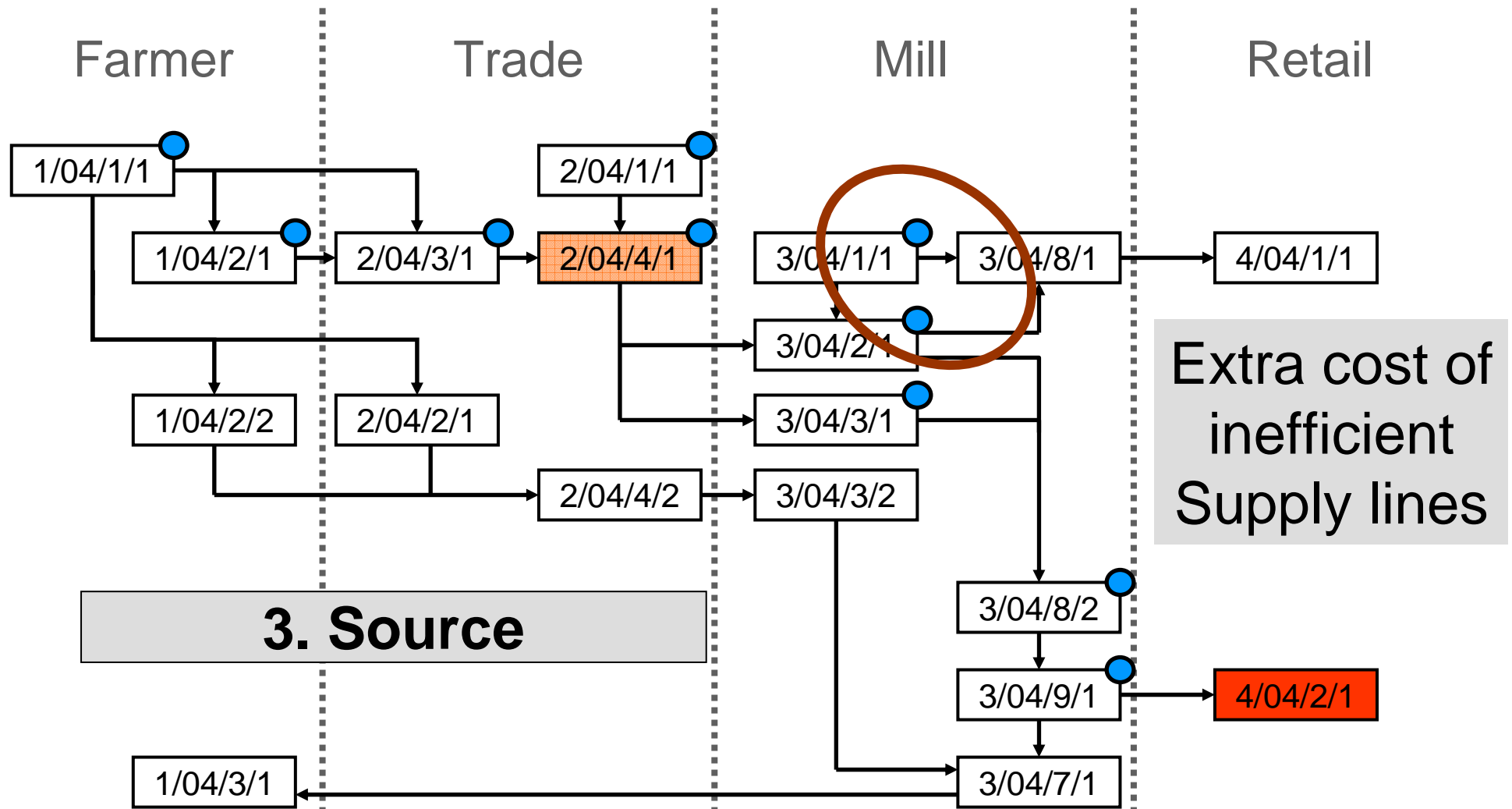

# Principle: Tracking/tracing/control

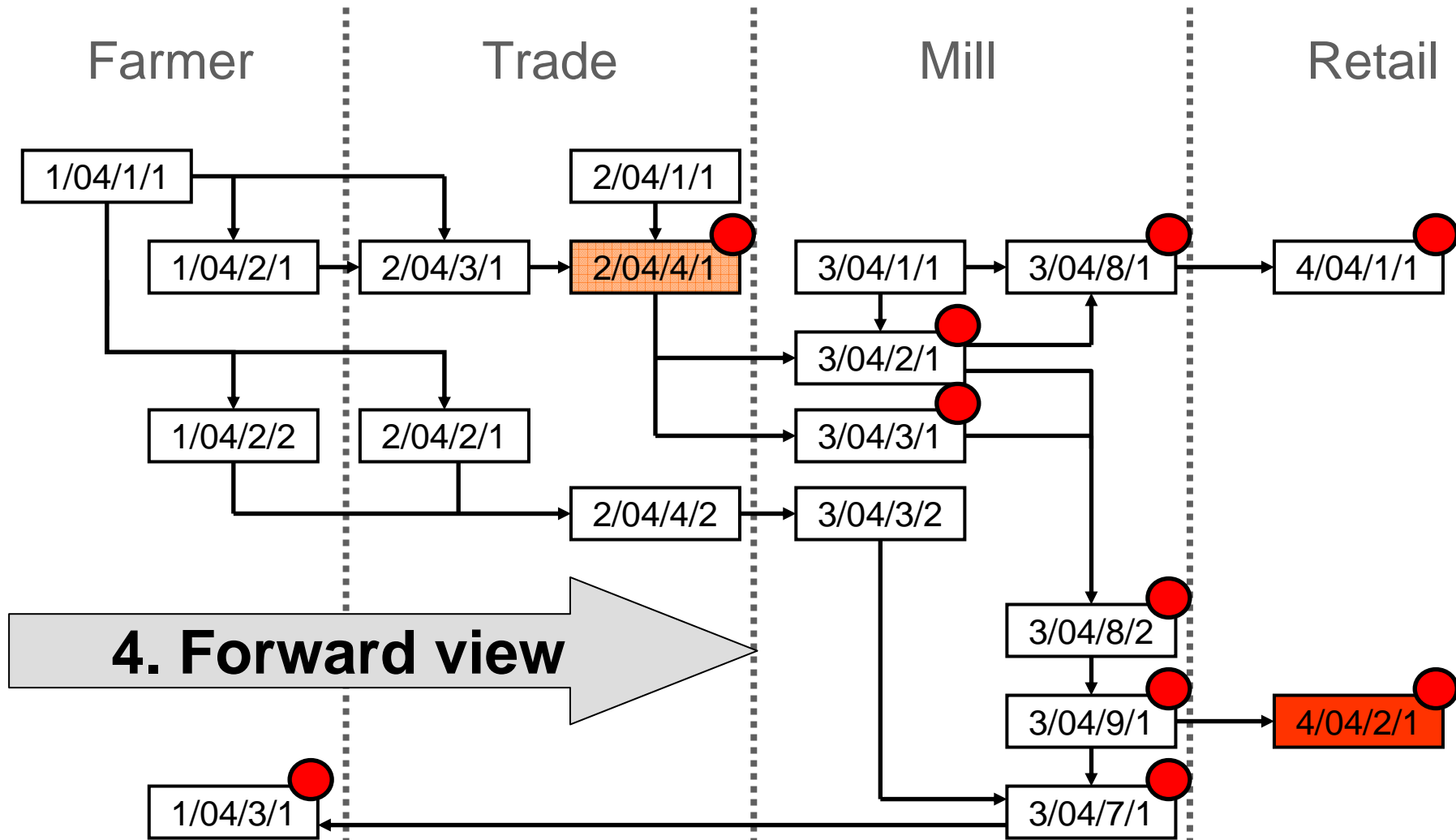

# Principle: Tracking/tracing/control

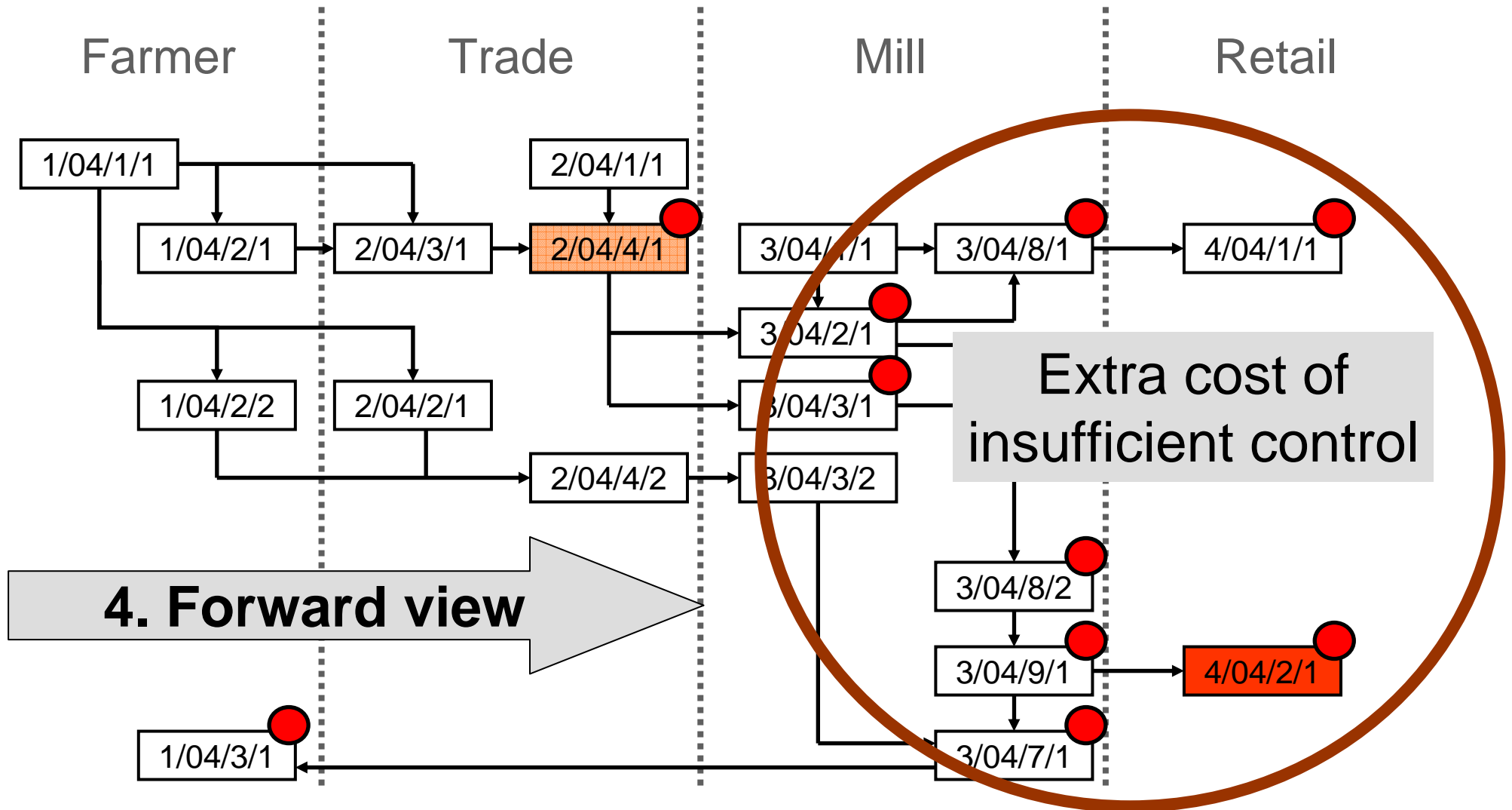

# Principle: Tracking/tracing/control

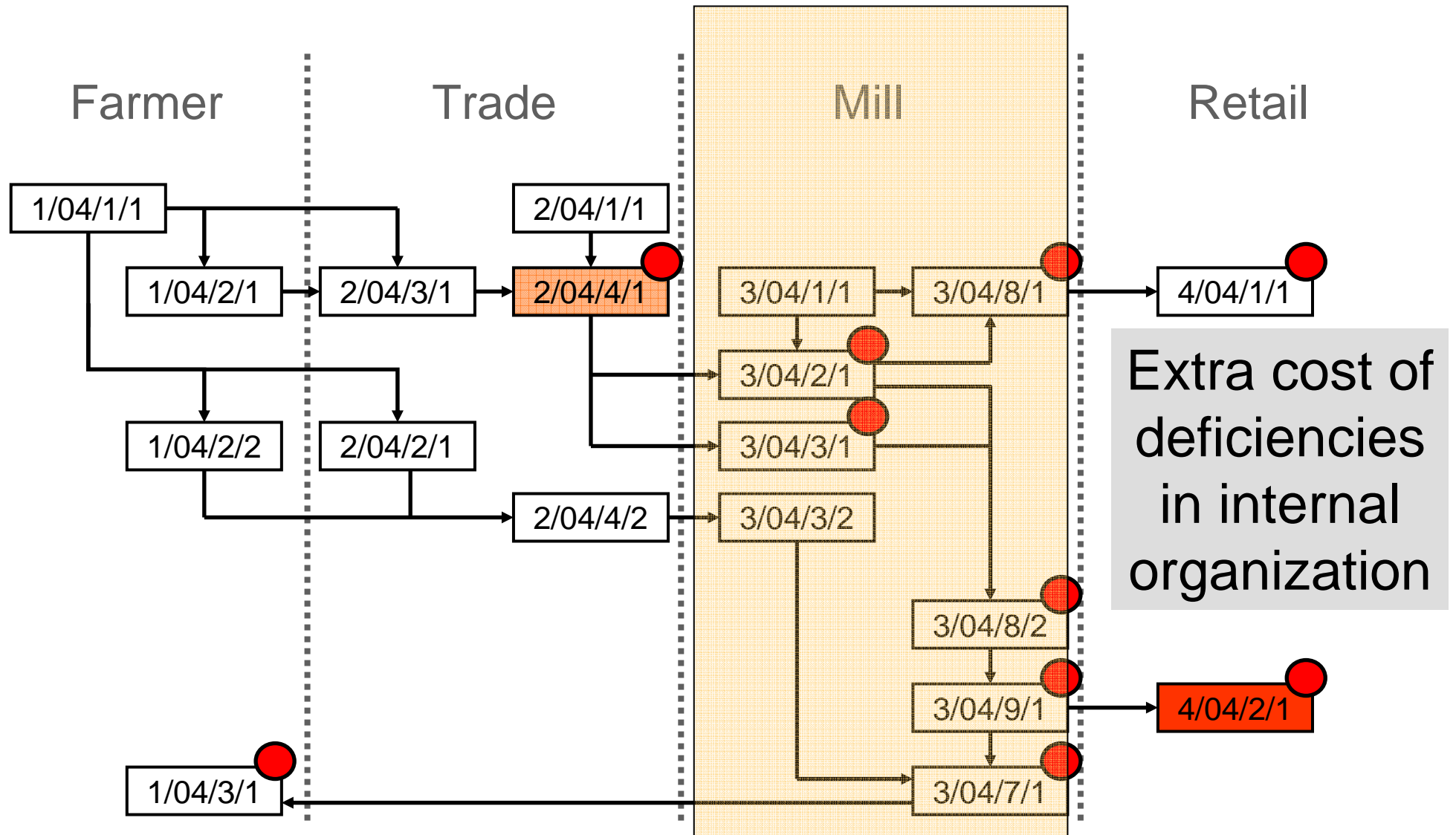

# How to move forward

- TT system technologies
- TT information principle (organization)
- **TT costs (real)**
- **TT benefit (potential)**
- Cost perceptions (low)
- Sector dependencies of benefits

## **Tracking and tracing costs**

- **Costs of control** (methods etc.)
- **Costs of tracking and tracing system**
- **Cost of process reorganization**
- Other costs (market loss etc.)

## **Tracking/tracing benefit potential**

- **Lower costs of recalls**
- **Lower probability of recalls**
- **Preferred supplier** (delivery guarantee)

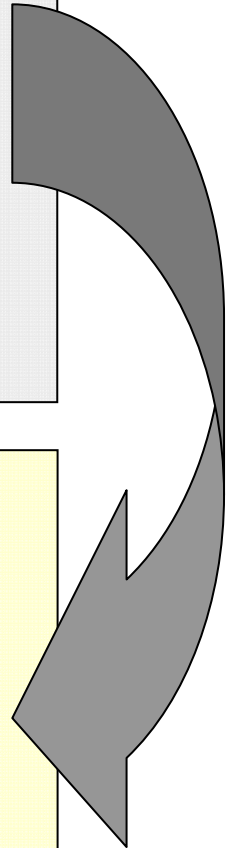

# Investments in new (improved) systems

Invest, if (benefit)

$$C(r_{tt}) + [C(tt) + C(e) + C(q)] < C(r_o)$$

benefit  
↓

Recall costs  
with new system

System costs

Recall costs  
with no system

But low  $p_r$

But low  $p_r$

**Conclusion:**

A **very substantial** reduction in recall costs is needed to make investments worthwhile

# Recall risk and costs

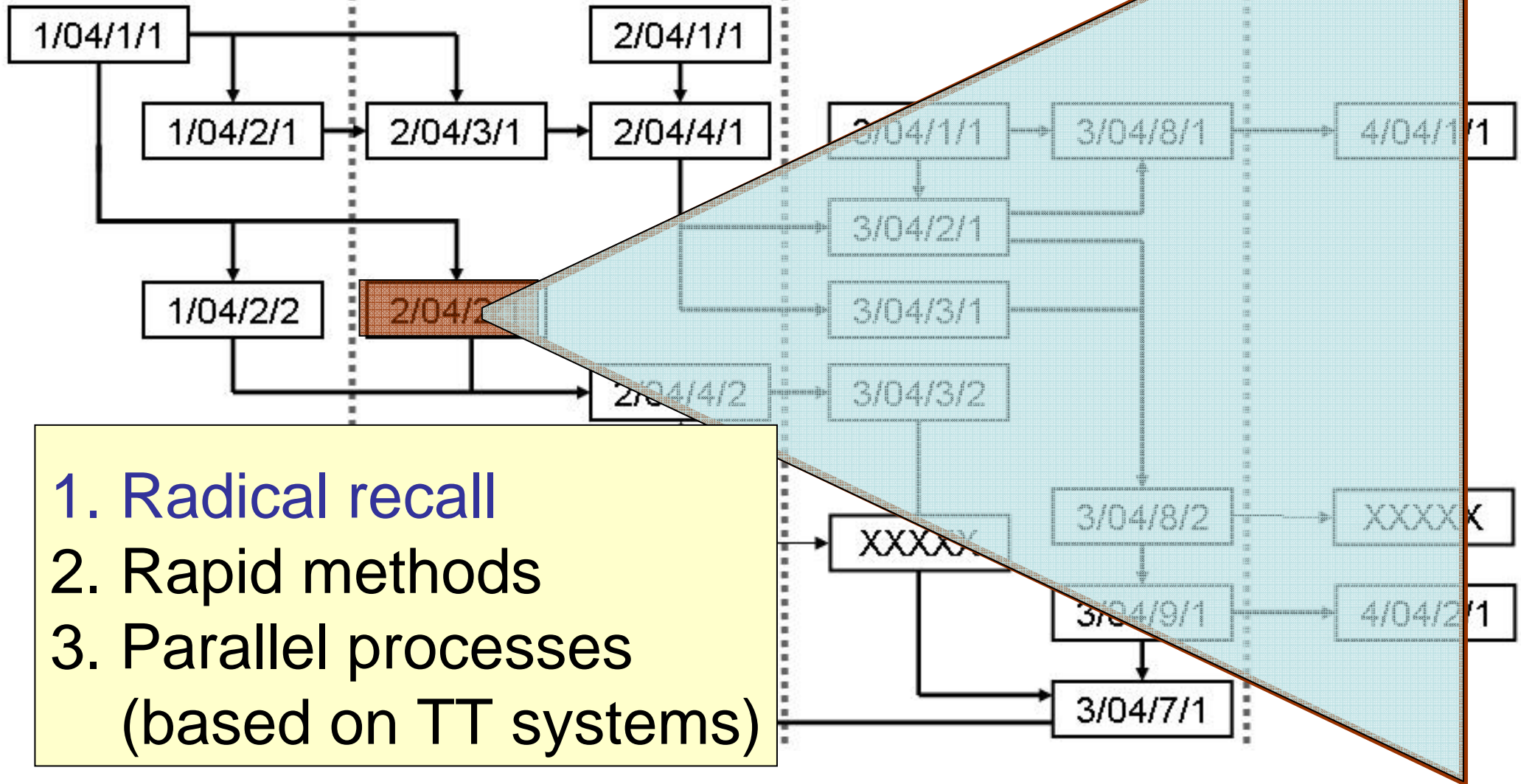

1. Radical recall
2. Rapid methods
3. Parallel processes  
(based on TT systems)

# Reduction of recall risk

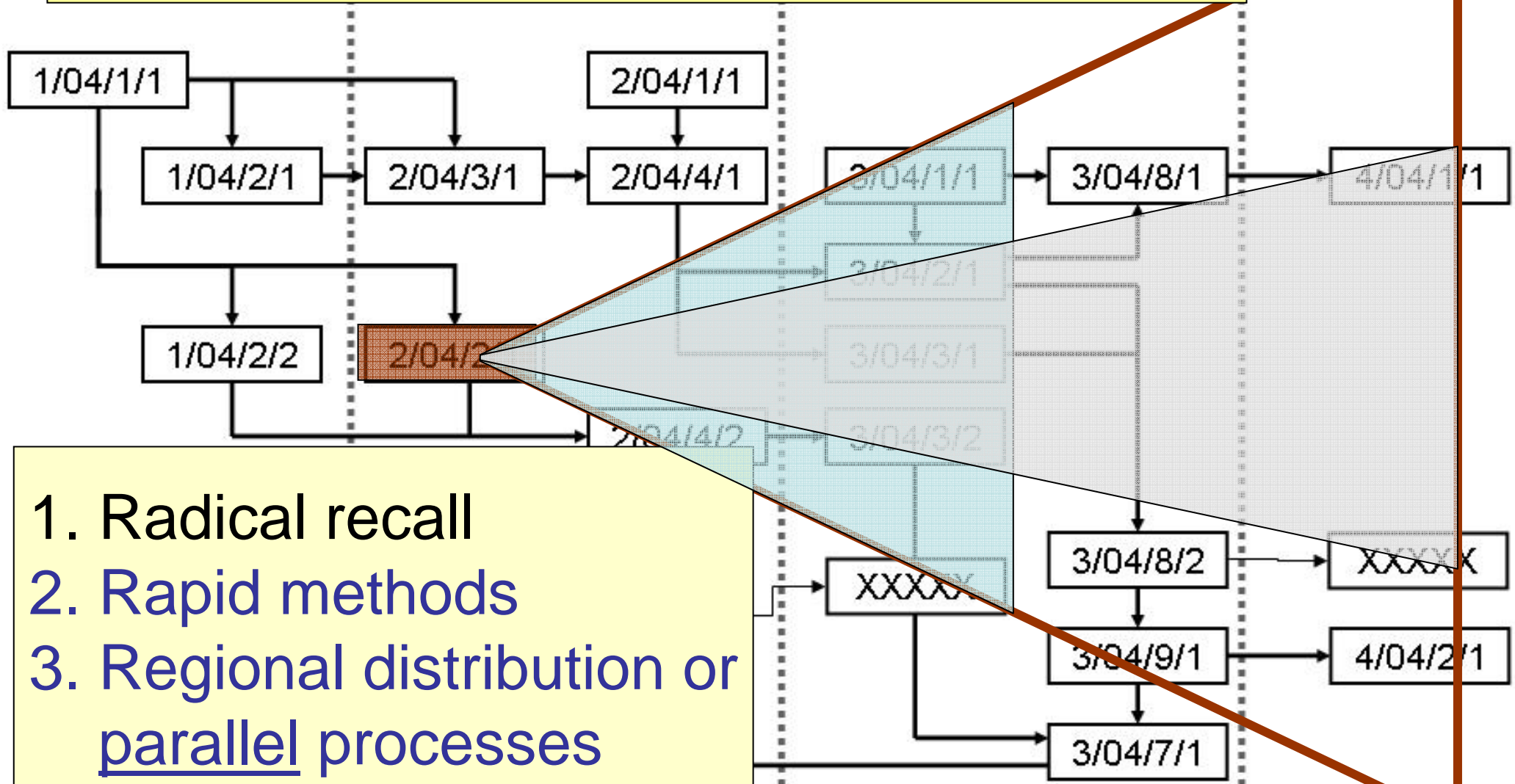

# Benefit potential through rapid methods

cost

Assure detection before consumer stage

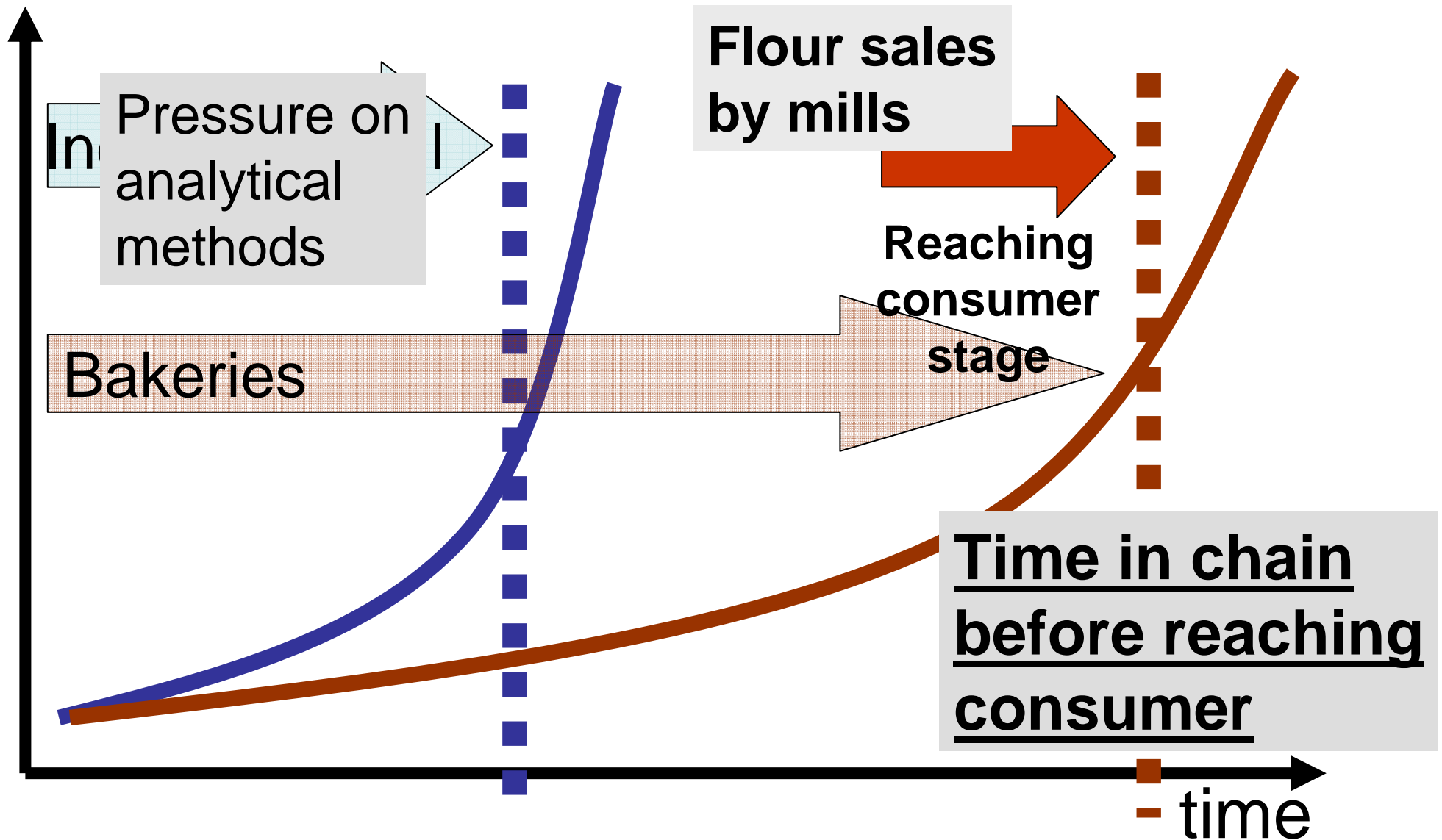

# Distribution and control: case study mill

## Case study - flour sales -

**Channel 1:**  
Flour to  
regional bakeries

→ Many days  
→ regional sales  
→ **good**

# Distribution and control: case study mill

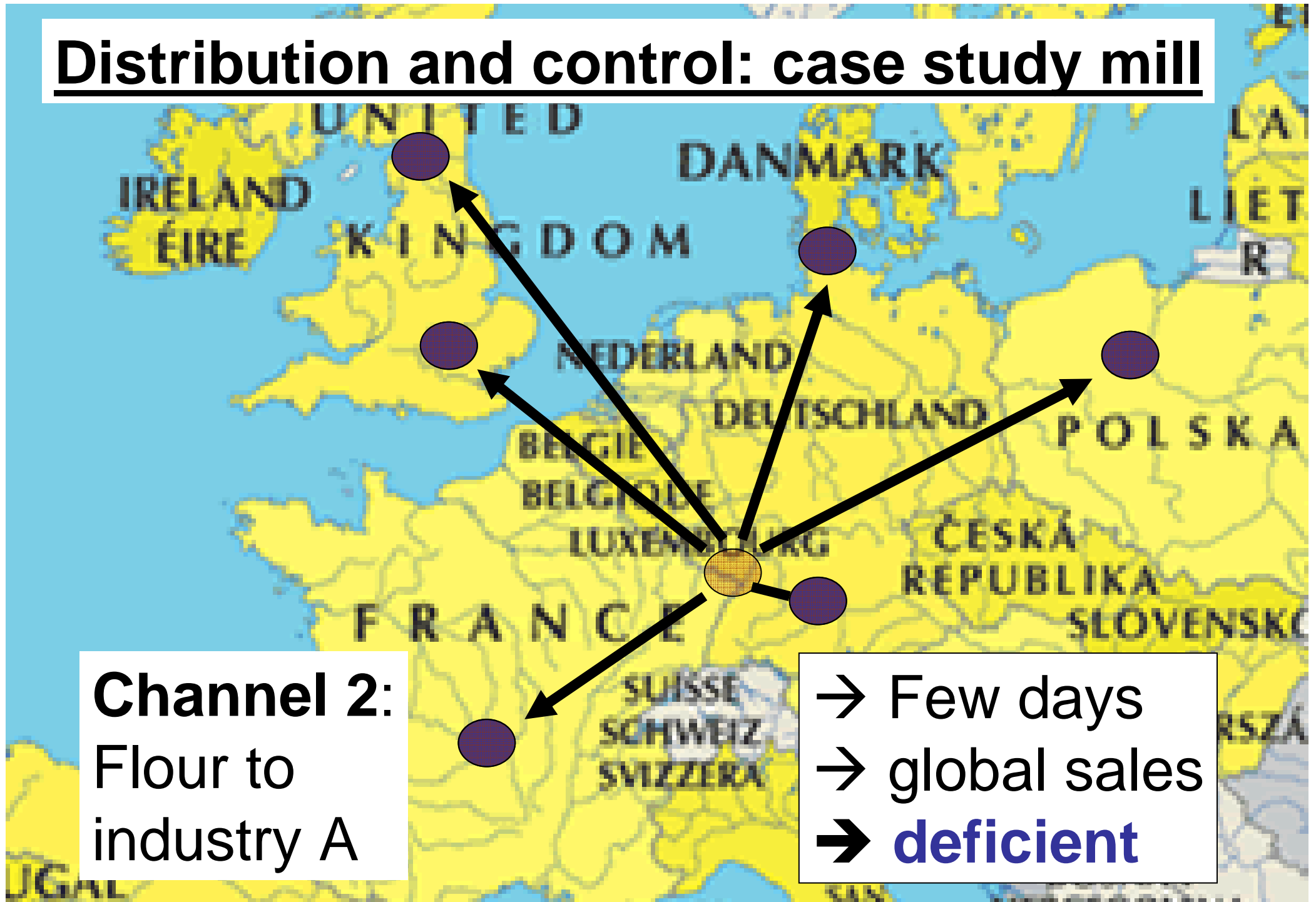

# Distribution and control: case study mill

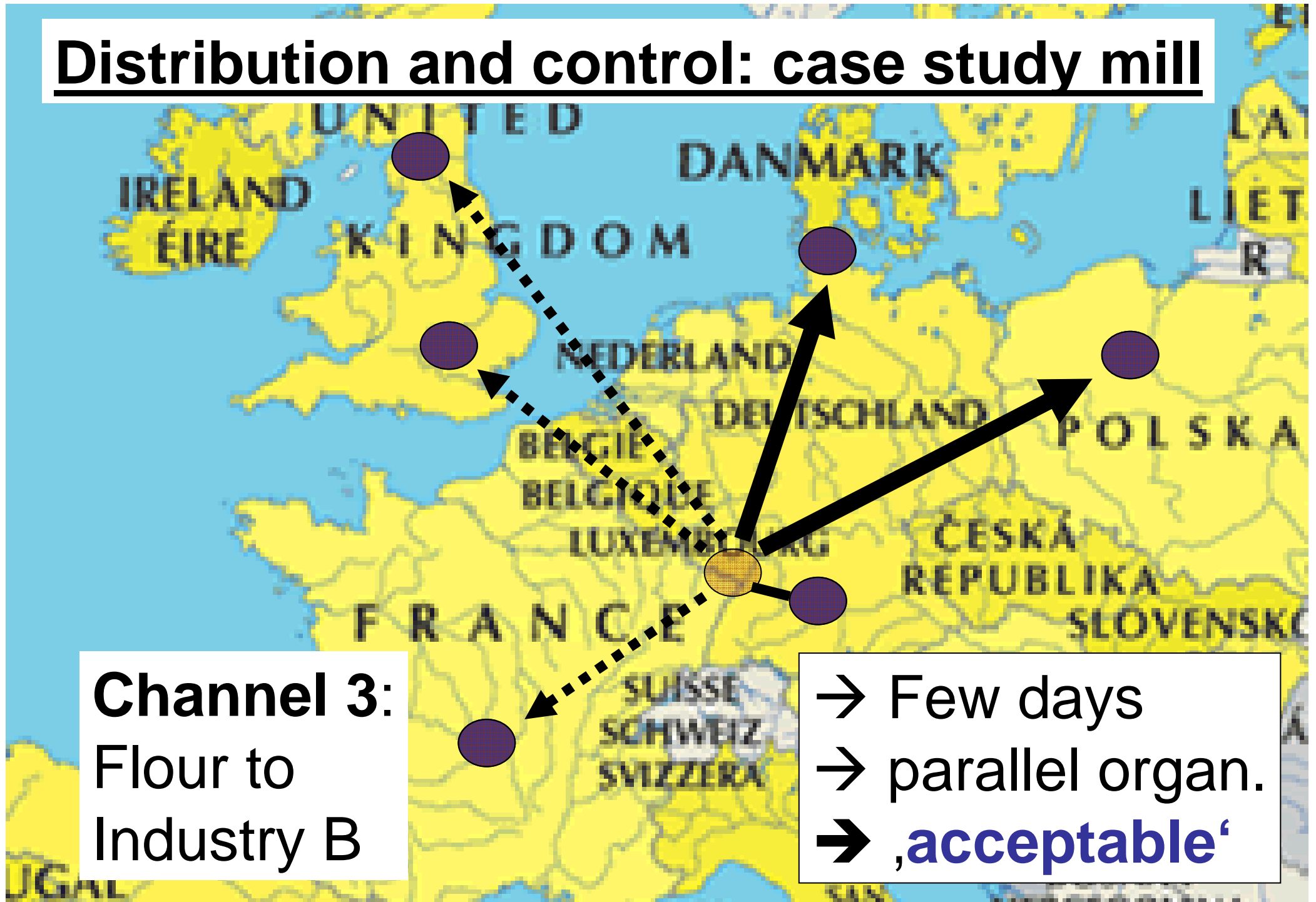

# Market stability (benefit)

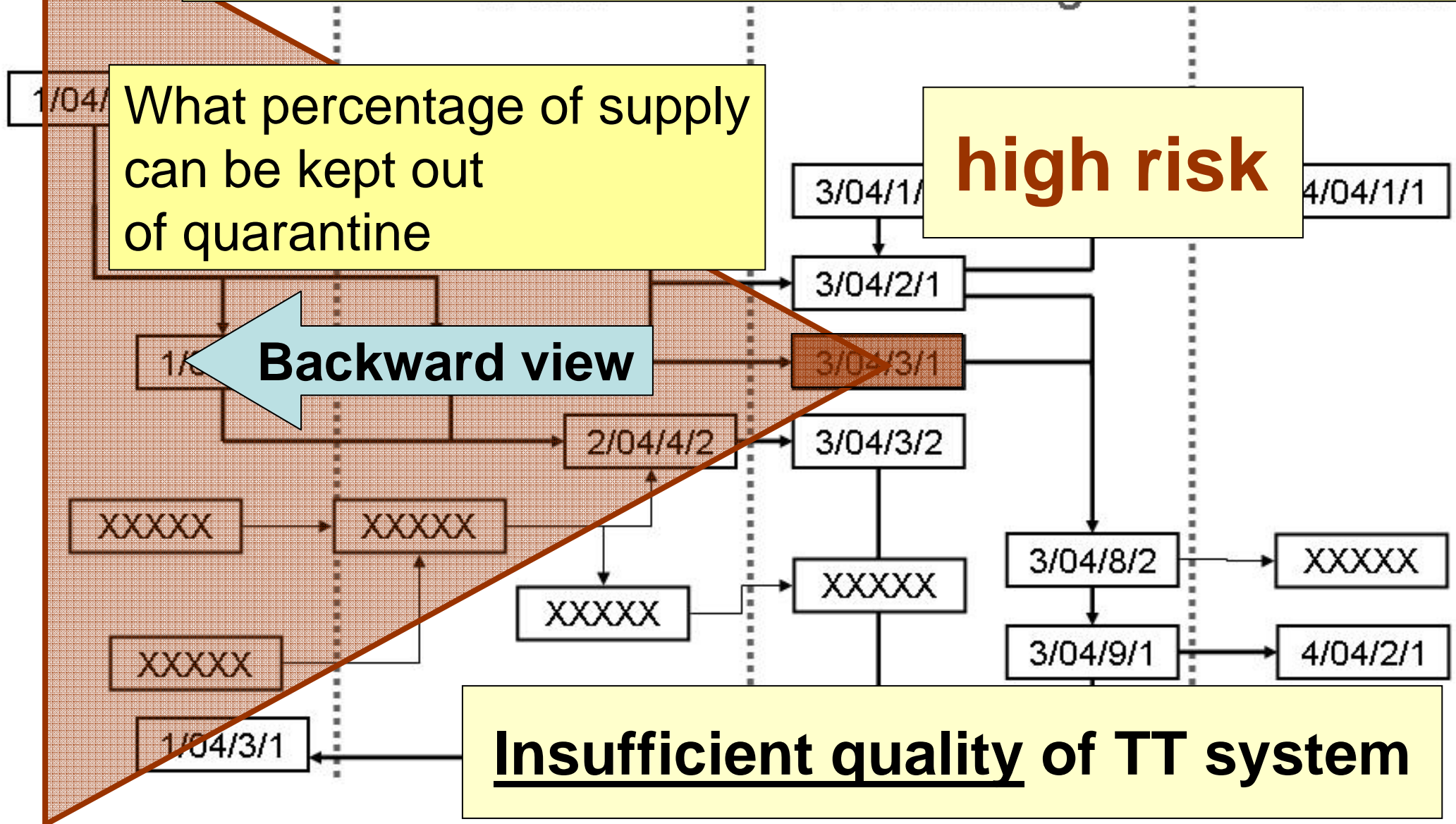

# Market stability (benefit)

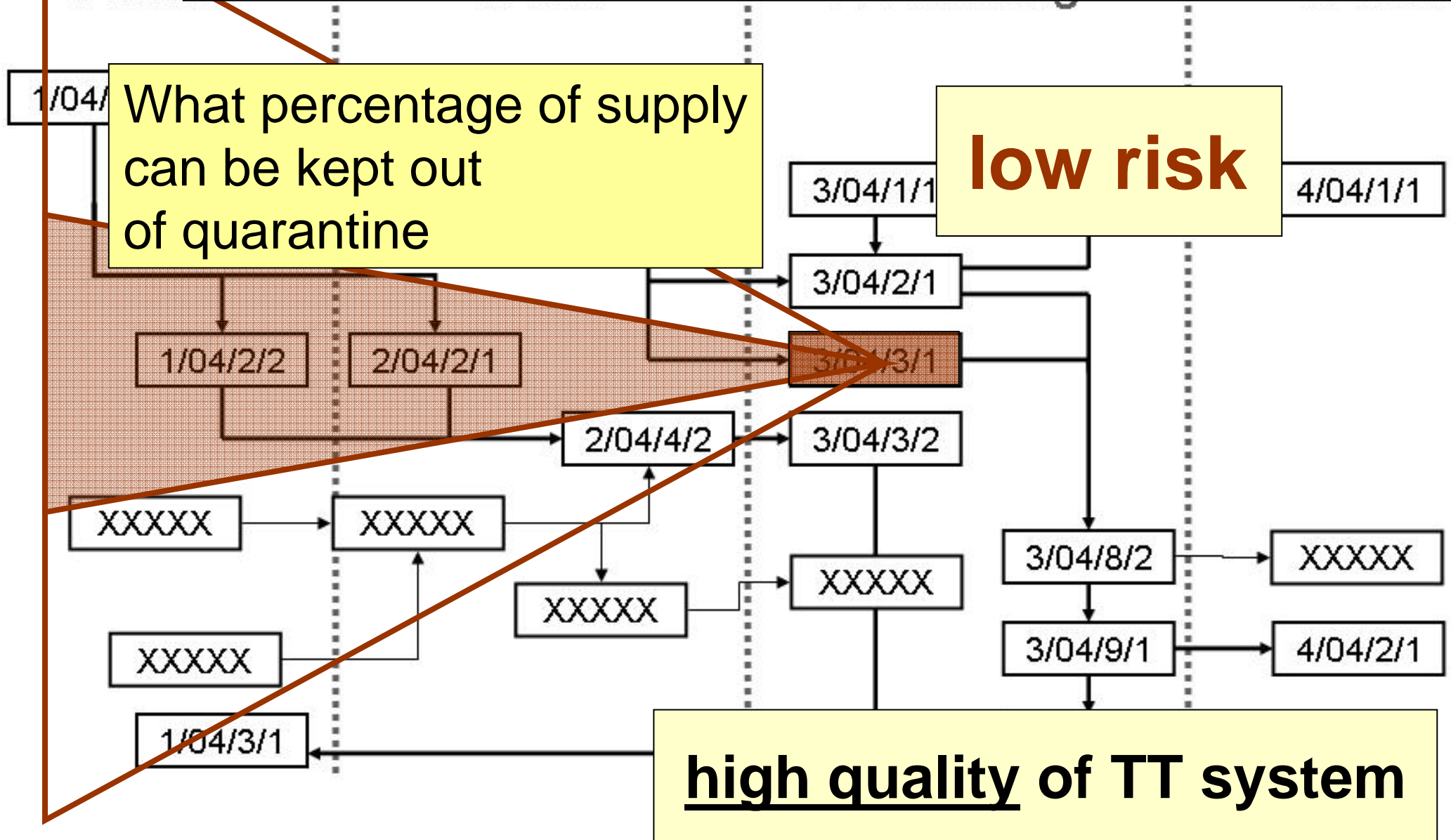

# Risk picture

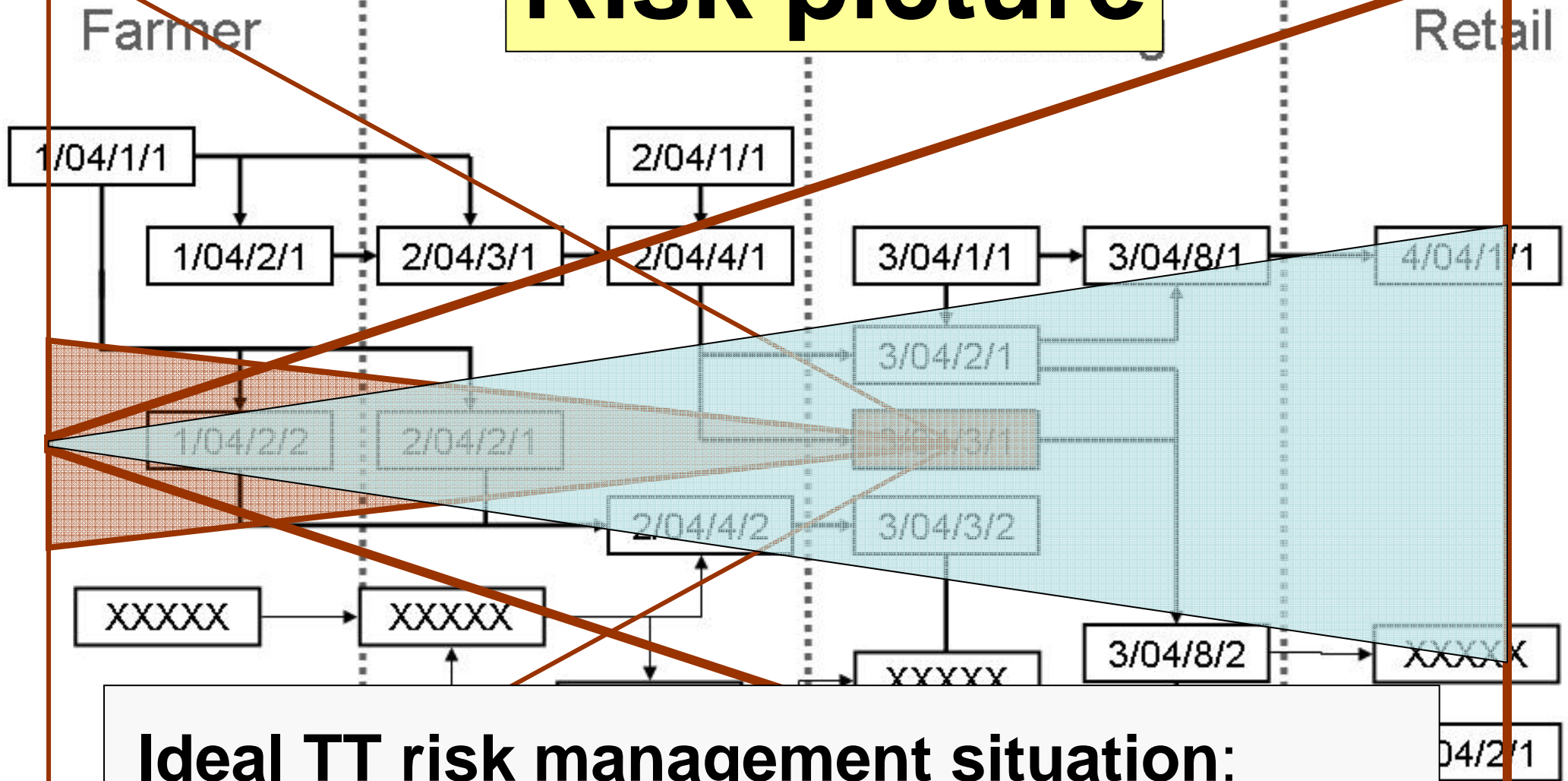

## Ideal TT risk management situation:

- Controlled (parallelized/focused) backward
- Controlled (parallelized/focused) forward

# How to move forward

- TT system technologies
- TT information principle (organization)
- TT costs (real)
- TT benefit (potential)
- **Cost perceptions**
- **Sector dependencies of benefits**

# The production - retail interdependency (failure at level of trade/mill)

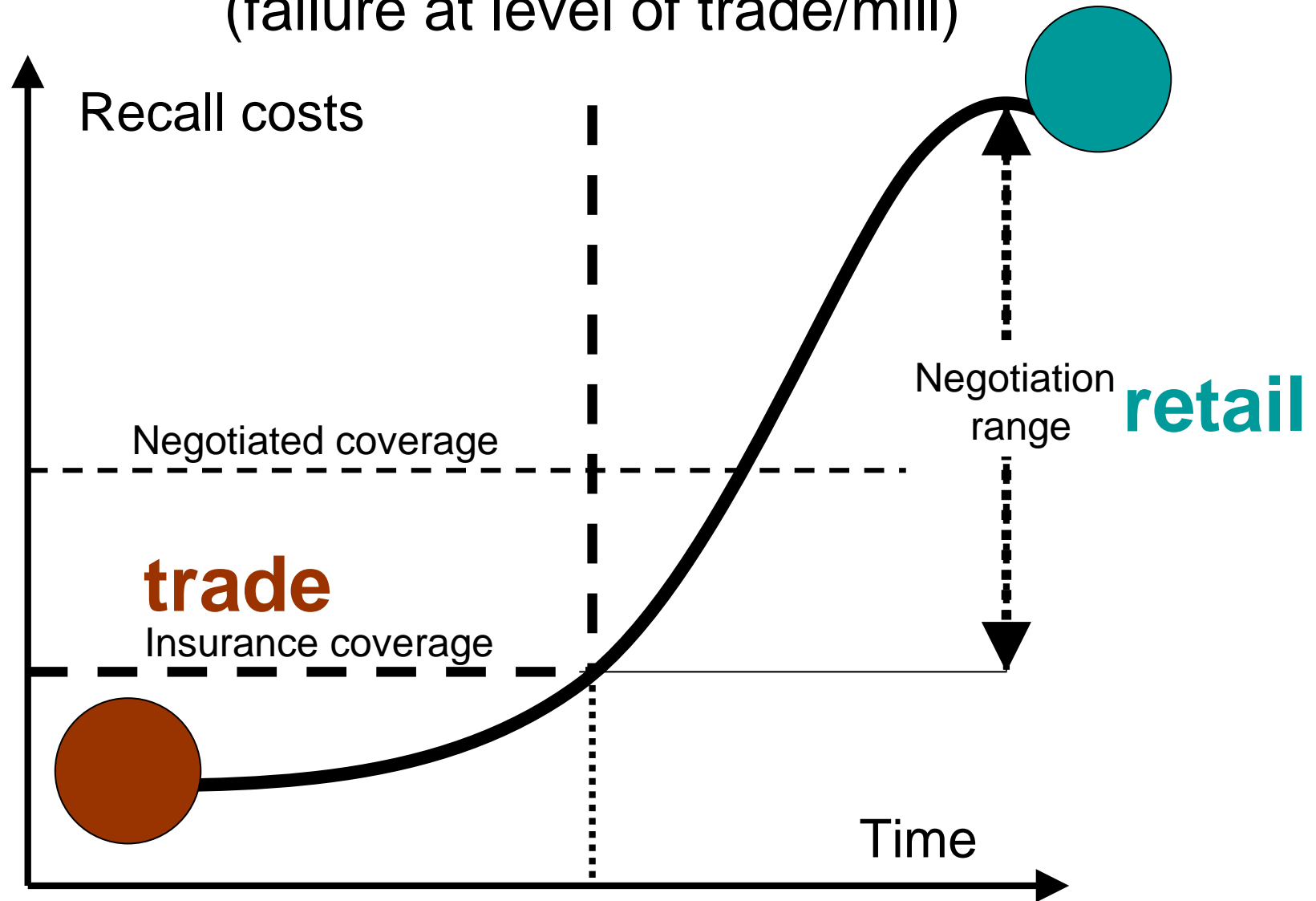

# The production - retail interdependency (failure at level of trade/mill)

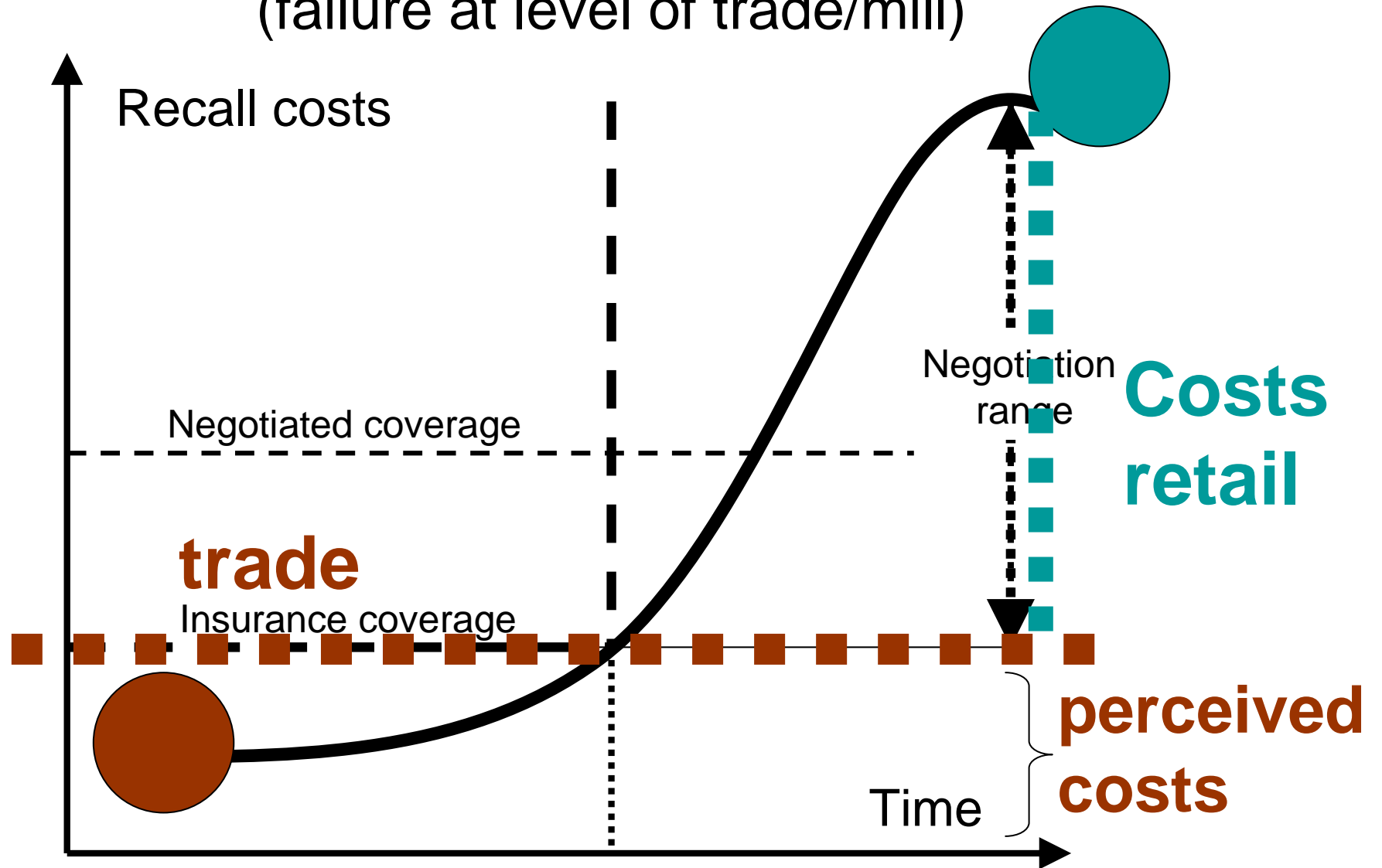

# Lost in the Food (Chain) Network ?

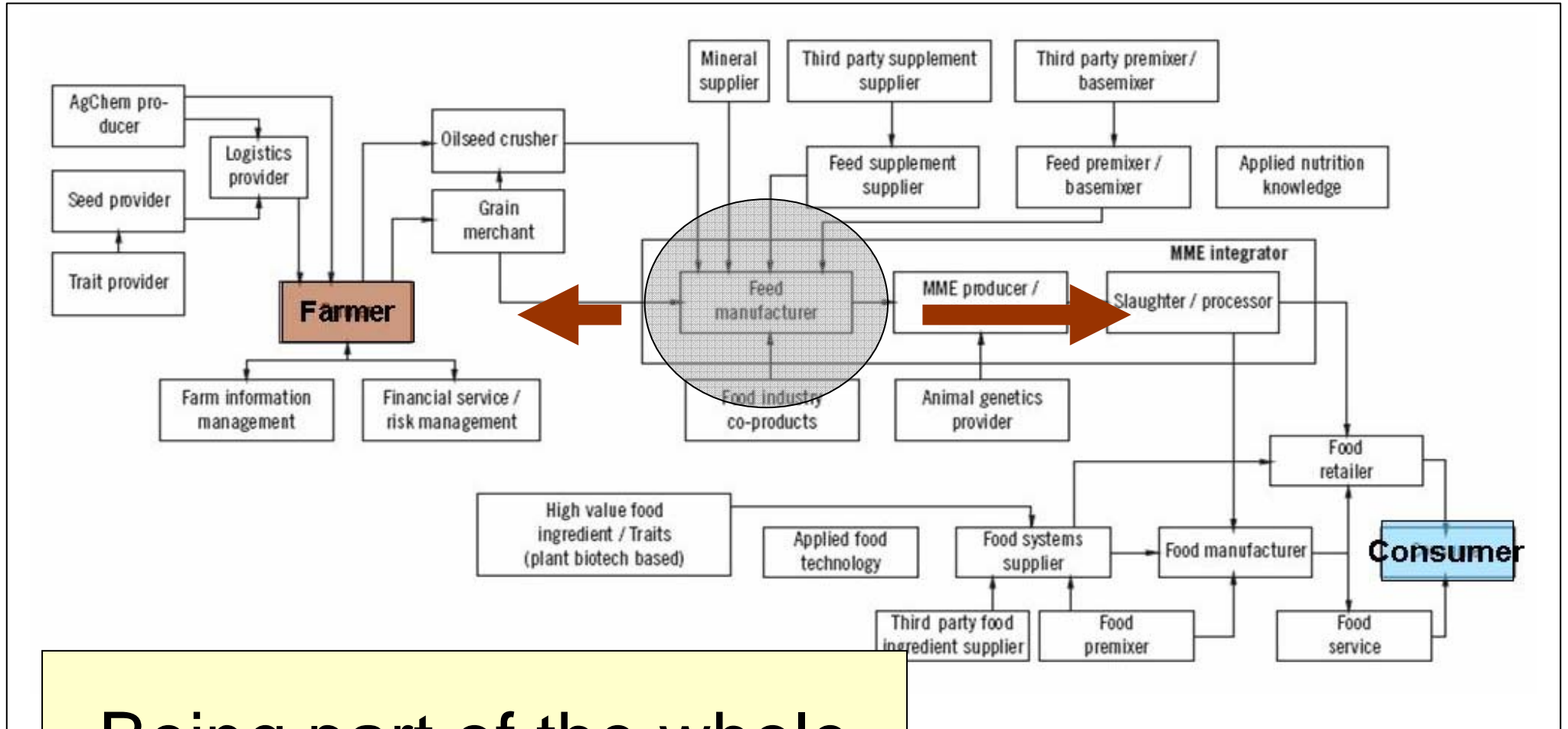

Being part of the whole

# Benefit tables (TT example) considering sector situation

Sector decision alternatives	Enterprise decision alternatives		
	Legal TT	Batch TT	Quality Batch TT
Sector quality TT			+++++
Sector batch TT		++	+++
Only legal requirem.	0	+	++

# Conclusion

Who gains: all (in the end)

But adoption problem: how to initiate

**Costs (now)**

→ investment by individuals

**Benefits (later on)**

→ only when **network** participate

**How to start?**

**operation/coordination**

→ cluster solutions, country solutions

→ sector solutions (cereal etc.)